



**BDI-REACH-Workshop
Einstieg in die Umsetzung
der neuen EU-Stoffpolitik**

Dokumentenerstellung zur Registrierung, REACH IT, IUCLID 5

Berlin, 28. 2./1.3. 2007

**Dr. Andrea Paetz
Bayer AG
Corporate Center
Governmental & Product Affairs**

IUCLID/ REACH IT

REACH IT ist ein RIP Projekt (**RIP** – **REACH I**mplementation **P**roject) – **RIP 2**

Wenn man von REACH IT spricht, meint man zwei Systeme:

- ❖ **IUCLID 5** –Datenbank
 - Datenbank, Maintool für die Registrierung (Industrie) - muss verwendet werden!
 - Tool für Dossiererstellung – Registrierdossier, Zulassungsantrag, C&L-Dossier (Industrie)
 - Zentrale Datenbank für alle Dossiers (Agentur)
- ❖ **REACH IT** – Tool der Agentur für Registrierung, Bewertung und Zulassung
 - Workflow System (Agentur)
 - Web-Portal (Agentur)
 - Öffentliche Datenbank (Agentur)
 - Einreichen von Datensätzen mit begrenzten Datenanforderungen (DU-CSR, DU-Registrierung, C&L-Inventory) (Industrie)
 - Statusverfolgung (Industrie)
 - Korrespondenz mit Agentur (Industrie)

IUCLID

The "big picture"

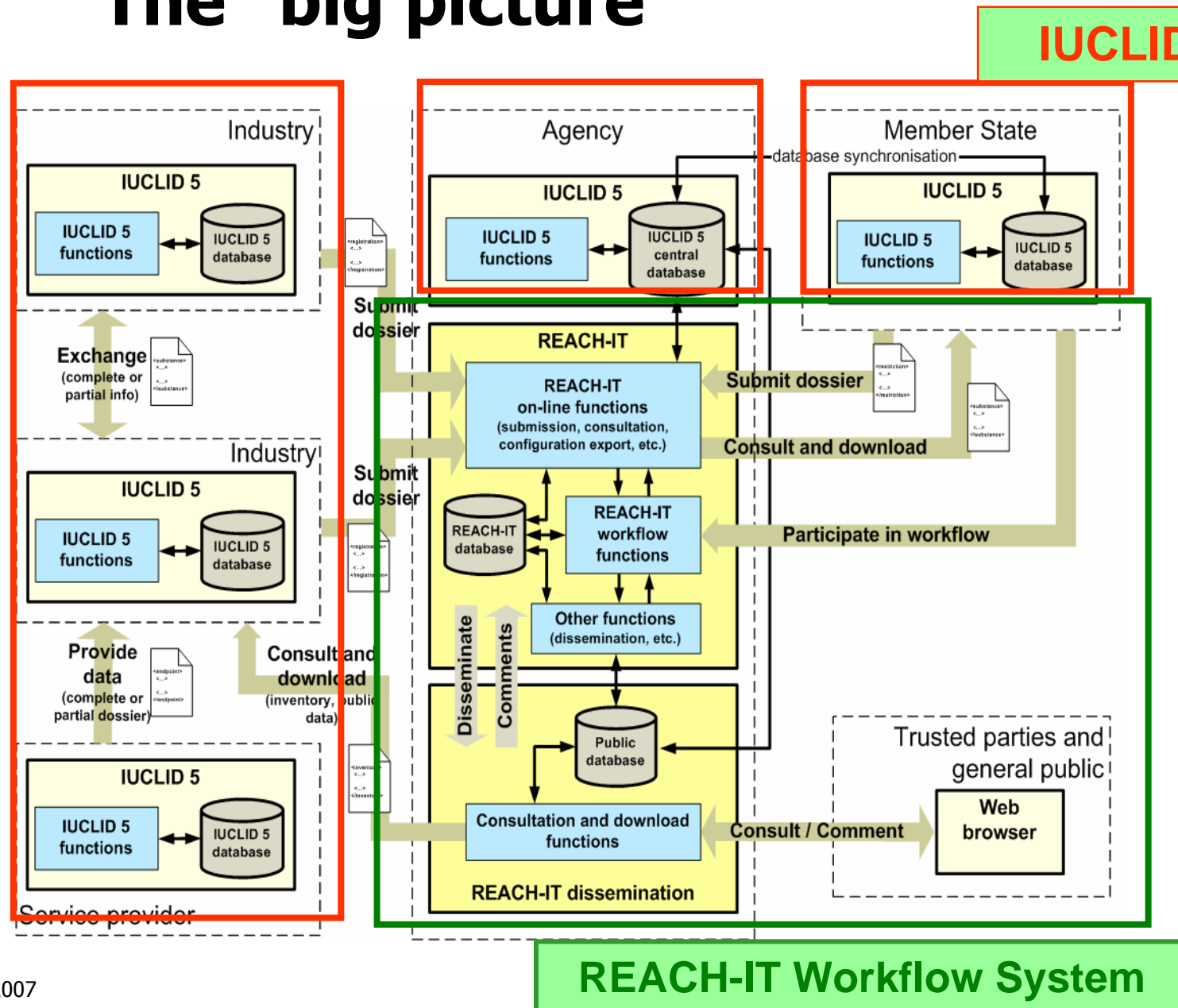

IUCLID5 dataflow

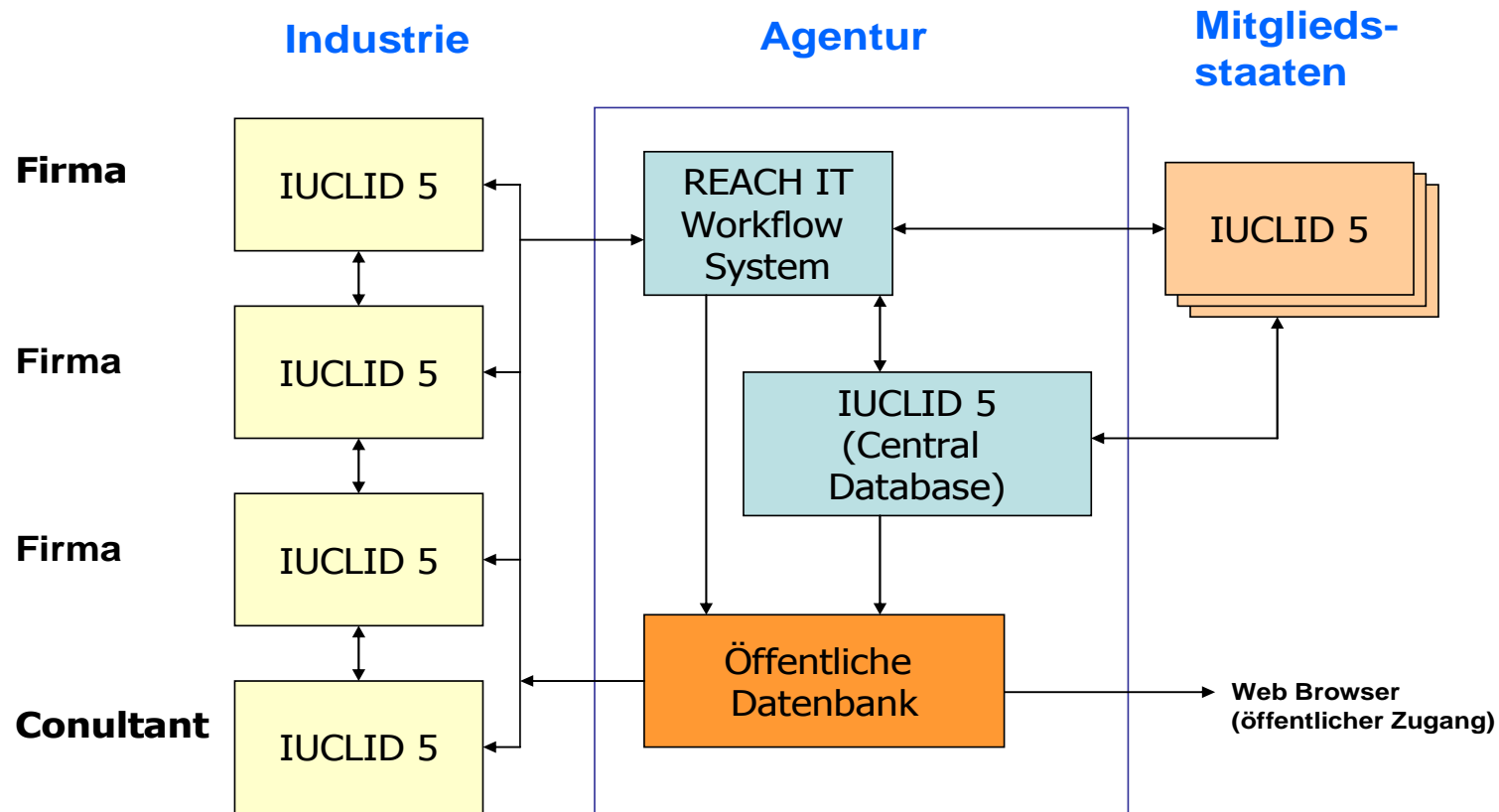

Datenerfassung/ -austausch

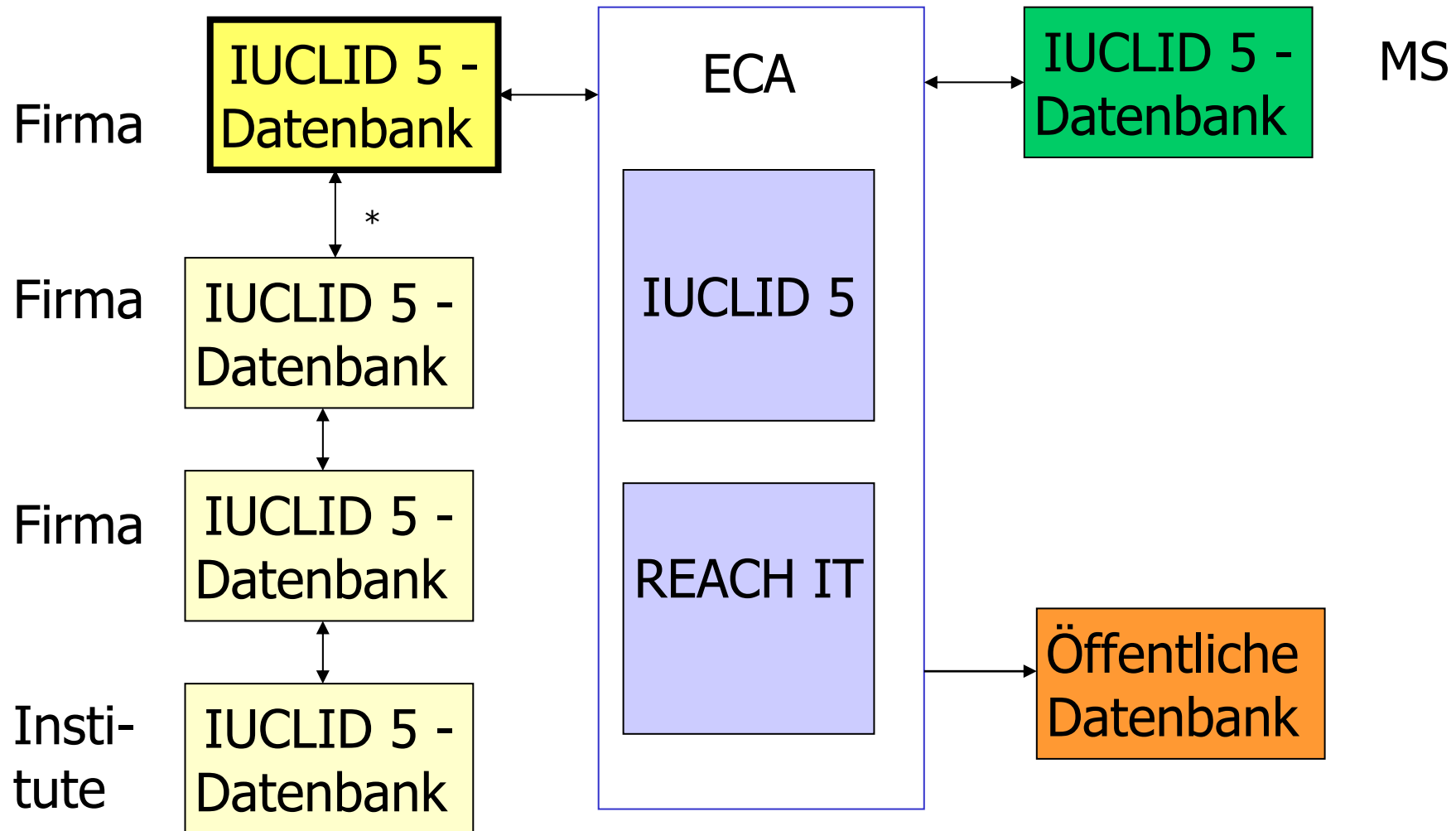

*Datenaustausch zwischen den Firmen-
Kompletttausch oder Teilaustausch

IUCLID ist das IT System (*Software & Datenbank*),
das für die Registrierung verwendet werden muss!

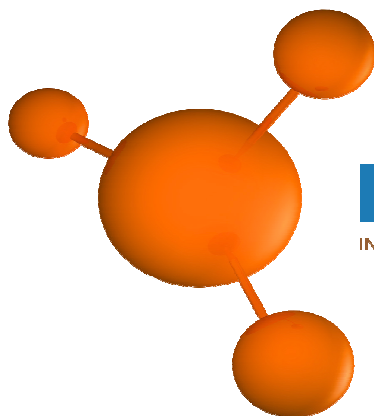

IUCLID 5
INTERNATIONAL UNIFORM CHEMICAL INFORMATION DATABASE

IUCLID 5 Datenmodell

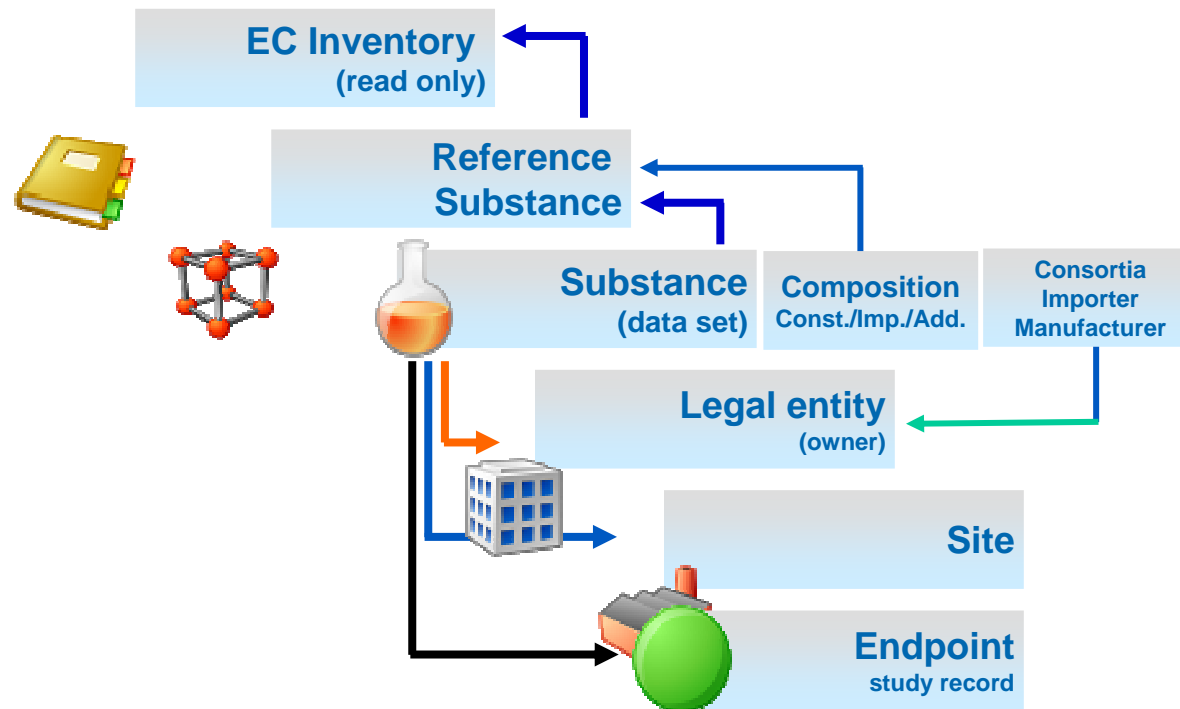

IUCLID5 – Data content

Chapter 1 – General Information

- 1.1 Identification (Substance, L
- 1.2 Composition
- 1.3 Identifiers
- 1.4 Analytical information
- 1.5 Joint Submission
- 1.6 Sponsors
- 1.7 Suppliers
- 1.8 Recipients
- 1.9 PPORD

Chapter 2 – C&L

- 2.1 GHS
- 2.2 EEC

Chapter 3 – Manufacture, Use a

- 3.1 Technological Process
- 3.2 Estimated Quantities
- 3.3. Sites
- 3.4 Form in the Supply Chain
- 3.5 Identified uses and Exp. Sc
- 3.6 Uses advised against
- 3.7 Waste from Production and
- 3.8 Exposure estimates
- 3.9 Biocidal information
- 3.10 Application for Authorisati

Chapter 4 - Physical & Chemical Properties

- 4.1 Appearance / Physical state
- 4.2 Melting Point
-
-

Chapter 5 - Environmental fate and pathways

- 5.1 Stability
- 5.2 Biodegradation
- 5.3 Bioaccumulation
- 5.4 Transport and distribution
- 5.5 Environmental data
- 5.6 Additional informat

Chapter 6 - Ecotoxicolo

- 6.1 Aquatic toxicity
- 6.2 Acute toxicity
- 6.3 Terrestrial toxicity
- 6.4

Chapter 7 - Toxicologic

- 7.1 Toxicokinetics, met
- 7.2 Acute toxicity
- 7.3 Irritation / corrosio
- 7.4

Chapter 8 - Analytical

Chapter 9 - Residues in food and feedingstuffs

- 9.1 Preliminary: Metabolism in livestock and crops
- 9.2 Preliminary: Residues in livestock and crops
- 9.3

Chapter 10 - Effectiveness against target organisms

Chapter 11 – Guidance on safe use

Chapter 12 – Literature search

Chapter 13 – Assessment Reports



Harmonisierte Datensätze

- ❖ Grundlage für IUCLID 5 sind die OECD Harmonized Templates.
- ❖ Die OECD hat in Zusammenarbeit mit den Behörden und der Industrie harmonisierte Datensätze entwickelt.
- ❖ Diese finden Verwendung für das Existing Chemicals Programme der OECD, ICCA HPV Initiative, das EPA HPV Program, die Biozidrichtlinie, die Pflanzenschutzrichtlinie und für REACH.
- ❖ Für jeden Endpunkt (intrinsische Eigenschaften) wurden die Felder genau spezifiziert (z. B. Testtyp, Methode, Spezies, Stamm, Anzahl der Tiere, Verabreichungsweg, Kontrollgruppe, Ergebnis, unterer Wert, oberer Wert, Freitexte ...)
- ❖ Zusätzlich sind Templates („Formblätter“) hinterlegt, um auch die Angaben im Freitext zu füllen.
- ❖ Diese Datensätze bilden die Grundlage von IUCLID. Sie wurden 1:1 umgesetzt.
- ❖ Es gibt verschiedene Sichten auf die Datenbank, so dass man nur bestimmte Endpunkte sehen kann (z.B. nur Annex VII für Stoffe zwischen 1 und 10 t)
- ❖ Man sieht aber immer den kompletten Endpunkt (alle Felder).



Tasks



Legal entity

Create and update company-/organisation-related information.

[New](#), [Update](#)



Substance

Create and update substance related information.

[New](#), [Update](#)



Template

Create and update template related information.

[New](#), [Update](#)



Dossier

Browse dossier data.

[Browse](#), [Compare](#)



Legal entity sites

Create and update legal entity sites.

[New](#), [Update](#)



Mixture

Create and update mixture related information.

[New](#), [Update](#)



Category

Create and update category related information.

[New](#), [Update](#)

Inventories



Inventories

View EC inventory related information.

[View](#)



Reference substance

Create and update reference substance related information.

[New](#), [Update](#)

Tools and administration



Migration tool

Do migration related work.

[Run migration tool](#)



Import

Import data from other IUCLID5 systems.

[Import](#)



Tools

Some useful tools.

[Backup](#), [Restore](#)



Manage users, roles, preferences etc.

[User preferences](#), [Set password](#), [User management](#), [Role management](#)

3-nitrotoluene / 3-nitrotoluene / EUROPEAN COMMISSION - European Chemicals Bureau - IUCLID 5

File Edit Go Window Help

Navigation

Query results Section tree

Completed

- 0 Related Information
- 1 General Substance Information
- 2 Manufacture, use and exposure
- 3 Physical and chemical properties
- 4 Environmental fate and pathways
- 5 Ecotoxicological information
- 6 Toxicological information
- 7 Preliminary: Analytical methods for detection and confirmation
- 8 Preliminary: Effectiveness against target organisms
- 9 Guidance on safe use
- 10 Literature search
- 11 Assessment Reports
- TechniData Test Section

Substance identification

Chemical name: 3-nitrotoluene

Legal entity flags:

Legal entity: EUROPEAN COMMISSION - European Chemicals Bureau / Ispra (VA) / Italy

Role in the supply chain

Role flags:

Role: Manufacturer Importer Only representative Downstream user

Reference substance

3-nitrotoluene

EC number	EC name
202-728-6	3-nitrotoluene

CAS number	CAS name

IUPAC name

Type of substance

Composition: other

Origin

Trade names

Name
Benzene,1-metil-3-nitro-

Add... View... Delete

Contact person

Information

Modification history Access Consultation Attachments Annotations Validation

Type: Substance

UUID: IUC4-6112928e-c7b7-3412-bc66-0792e772144c

Dossier UUID: 0

Sealed

Subset of original

3-nitrotoluene / 3-nitrotoluene / EUROPEAN COMMISSION - Eu

File Edit Go Window Help

Navigation

Query results Section tree

Complete

- 0 Related Information
- 1 General Substance Information
- 2 Manufacture, use and exposure
- 3 Physical and chemical properties
 - 3.1 Appearance/physical state/colour
 - 3.2 Melting point/freezing point
 - 3.3 Boiling point
 - 3.4 Density (Bulk density, density or relative densi
 - 3.5 Particle size distribution (Granulometry)
 - 3.6 Vapour pressure
 - 3.7 Partition coefficient
 - 3.8 Water solubility
 - 3.9 Solubility in organic solvents / fat solubility
 - 3.10 Surface tension
 - 3.11 Flash point
 - 3.12 Auto flammability
 - 3.13 Flammability
 - 3.14 Explosiveness
 - 3.15 Oxidising properties
 - 3.16 Oxidation reduction potential
 - 3.17 Stability in organic solvents and identity of re
 - 3.18 Reactivity towards container material
 - 3.19 Thermal stability
 - 3.20 Non-saturated pH
 - 3.21 Dissociation constant
 - 3.22 Viscosity
 - 3.23 Additional physico-chemical information

List

Choose an item

TechniData Test

Complete

REACH joint submission for registration dossier (general case)

REACH Registration Annex V - min. requirement (ton1+)

REACH Registration Annex V - complete (ton1+)

REACH Registration Annex VI (ton 10+)

REACH Registration Annex VII (ton 100+)

REACH Registration Annex VIII (tons 1000+)

REACH joint submission for registration dossier (intermediates)

REACH Intermediates: on site isolated above 1t (Art.15)

REACH Intermediates: transported isolated 1-1000t (Art. 16)

REACH Intermediates: transported isolated above 1000t (Art. 16)

REACH PPORD (Art. 7)

REACH Applic. Autho. (Art. 59)

REACH DU Report (Art. 35)

REACH Notification of substance in article (Art. 6(3))

REACH C&L notification (Art. 110) Art. 35 for DU

REACH Annex 14 type of dossier

OECD

Ok Cancel

3-nitrotoluene / 3-nitrotoluene / EUROPEAN COMMISSION - Eu

File Edit Go Window Help

Navigation

Query results Section tree

REACH Registration Annex VII (ton 100+)

- 0 Related Information
- 1 General Substance Information
- 2 Manufacture, use and exposure
- 3 Physical and chemical properties
 - 3.1 Appearance/physical state/colour
 - 3.2 Melting point/freezing point
 - 3.3 Boiling point
 - 3.4 Density (Bulk density, density or relative density)
 - 3.5 Particle size distribution (Granulometry)
 - 3.6 Vapour pressure
 - 3.7 Partition coefficient
 - 3.8 Water solubility
 - 3.9 Solubility in organic solvents / fat solubility
 - 3.10 Surface tension
 - 3.11 Flash point
 - 3.12 Auto flammability
 - 3.13 Flammability
 - 3.14 Explosiveness
 - 3.15 Oxidising properties
 - 3.16 Oxidation reduction potential
 - 3.17 Stability in organic solvents and identity of reagents
 - 3.18 Reactivity towards container material
 - 3.19 Thermal stability
 - 3.20 Non-saturated pH
 - 3.21 Dissociation constant
 - 3.22 Viscosity
 - 3.23 Additional physico-chemical information

Substa

Substa

Chemical

Legal ent

Leg

Role in

Ro

Referen

3-nitro

EC num

202-72

CAS num















IUPAC n





Type of

Comp

Trade n

Respon

-  2-furaldehyde
-  2-methylpropan-1-ol
-  3,3'-dichlorobenzidine
-  3,4-dichloroaniline
-  3-aminomethyl-3,5,5-trimethylcyclohexylamine
-  **3-nitrotoluene**
-  4-nitrotoluene
-  4-nitrotoluene
-  4-tert-butyltoluene
-  6-ethyl-2-toluidine
-  [(3a,4,5,6,7,7a-hexahydro-4,7-m
-  [[(phosphonomethyl)imino]bis(e
-  acrylic acid, monoester with propane-1,2-diol
-  alpha,alpha,alpha-trichlorotoluene

-  Open
-  Print
-  Export
-  **Create Dossier**

-  Delete

CAS number

IUPAC name

type of substance

Composition

Origin

trade names

Benzene, 1-metil-

Dossier creation assistant

Please verify all dependant documents for dossier creation.

Documents selected for dossier creation:

Export	Filter	Document	Endpoint	Last modification	Origin
<input checked="" type="checkbox"/>	<input checked="" type="checkbox"/>	Substance 3-nitrotoluene / 3-nitrotoluene...	---	2006-07-17 14:02:45 ...	
<input checked="" type="checkbox"/>	<input checked="" type="checkbox"/>	Reference substance 3-nitrotoluene	---	2000-02-11 00:00:00 ...	
<input checked="" type="checkbox"/>	<input checked="" type="checkbox"/>	Legal entity European Chemicals Bureau / I...	---	2006-05-27 10:08:59 ...	
<input checked="" type="checkbox"/>	<input checked="" type="checkbox"/>	Legal entity EUROPEAN COMMISSION - Eur...	---	2000-02-11 00:00:00 ...	
<input checked="" type="checkbox"/>	<input checked="" type="checkbox"/>	Study Appearance/physical state/colour.0...	3.1 Appearance/physical state/colour	2006-07-17 14:02:45 ...	Substance 3-nitrotoluen...
<input checked="" type="checkbox"/>	<input checked="" type="checkbox"/>	Study Repeated dose toxicity: inhalation.001	6.5.3 Repeated dose toxicity: inhalation	1994-05-30 00:00:00 ...	Substance 3-nitrotoluene
<input checked="" type="checkbox"/>	<input checked="" type="checkbox"/>	Study Toxicity to reproduction.001	6.8.1 Toxicity to reproduction	1994-05-30 00:00:00 ...	Substance 3-nitrotoluene
<input checked="" type="checkbox"/>	<input checked="" type="checkbox"/>	Study Repeated dose toxicity: dermal.001	6.5.2 Repeated dose toxicity: dermal	1994-05-30 00:00:00 ...	Substance 3-nitrotoluene
<input checked="" type="checkbox"/>	<input checked="" type="checkbox"/>	Study Acute toxicity: oral.001	6.2.1 Acute toxicity: oral	1994-05-20 00:00:00 ...	Substance 3-nitrotoluene
<input checked="" type="checkbox"/>	<input checked="" type="checkbox"/>	Study Toxicity to microorganisms.001	5.1.7 Toxicity to microorganisms	1994-05-28 00:00:00 ...	Substance 3-nitrotoluene
<input checked="" type="checkbox"/>	<input checked="" type="checkbox"/>	Study Water solubility.001	3.8 Water solubility	1994-03-07 00:00:00 ...	Substance 3-nitrotoluene
<input checked="" type="checkbox"/>	<input checked="" type="checkbox"/>	Study Bioaccumulation: aquatic.001	4.3.1 Bioaccumulation: aquatic	1994-05-28 00:00:00 ...	Substance 3-nitrotoluene
<input checked="" type="checkbox"/>	<input checked="" type="checkbox"/>	Study Solubility in organic solvents / fat so...	3.9 Solubility in organic solvents / fat ...	1994-03-07 00:00:00 ...	Substance 3-nitrotoluene
<input checked="" type="checkbox"/>	<input checked="" type="checkbox"/>	Study Acute toxicity: other routes.001	6.2.4 Acute toxicity: other routes	1994-05-30 00:00:00 ...	Substance 3-nitrotoluene
<input checked="" type="checkbox"/>	<input checked="" type="checkbox"/>	Study Acute toxicity: dermal.001	6.2.3 Acute toxicity: dermal	1994-05-20 00:00:00 ...	Substance 3-nitrotoluene
<input checked="" type="checkbox"/>	<input checked="" type="checkbox"/>	Study Biodegradation in water and sedime...	4.2.2 Biodegradation in water and sedi...	1994-05-28 00:00:00 ...	Substance 3-nitrotoluene
<input checked="" type="checkbox"/>	<input checked="" type="checkbox"/>	Study Eye irritation.001	6.3.2 Eye irritation	1994-05-30 00:00:00 ...	Substance 3-nitrotoluene
<input checked="" type="checkbox"/>	<input checked="" type="checkbox"/>	Study Flash point.001	3.11 Flash point	1994-03-07 00:00:00 ...	Substance 3-nitrotoluene
<input checked="" type="checkbox"/>	<input checked="" type="checkbox"/>	Study Short-term toxicity to aquatic invert...	5.1.3 Short-term toxicity to aquatic in...	1994-05-31 00:00:00 ...	Substance 3-nitrotoluene
<input checked="" type="checkbox"/>	<input checked="" type="checkbox"/>	Study Partition coefficient.001	3.7 Partition coefficient	1994-03-07 00:00:00 ...	Substance 3-nitrotoluene
<input checked="" type="checkbox"/>	<input checked="" type="checkbox"/>	Study Long-term toxicity to aquatic invert...	5.1.4 Long-term toxicity to aquatic in...	1994-05-31 00:00:00 ...	Substance 3-nitrotoluene
<input checked="" type="checkbox"/>	<input checked="" type="checkbox"/>	Study Toxicity to aquatic plants other than...	5.1.6 Toxicity to aquatic plants other t...	1994-05-28 00:00:00 ...	Substance 3-nitrotoluene
<input checked="" type="checkbox"/>	<input checked="" type="checkbox"/>	Study Boiling point.001	3.3 Boiling point	1994-05-28 00:00:00 ...	Substance 3-nitrotoluene
<input checked="" type="checkbox"/>	<input checked="" type="checkbox"/>	Study Genetic toxicity in vitro.001	6.6.1 Genetic toxicity in vitro	1994-05-30 00:00:00 ...	Substance 3-nitrotoluene
<input checked="" type="checkbox"/>	<input checked="" type="checkbox"/>	Study Density (Bulk density, density or rela...	3.4 Density (Bulk density, density or r...	1994-05-28 00:00:00 ...	Substance 3-nitrotoluene

- not included (because of filter settings)
- partially included (reduced information)
- completely included
- cannot be included (error)

1-2-3-4-5
Select the documents

< Back Next > Finish Cancel

- 1,2-dichloroethane
- 1,2-dichloroethane
- 1,3-dimethylbenzene
- 1,3-dinitrobenzene
- 1-chloro-2-methyl-2-propanol
- 2(or 4)-chlorophenol
- 2,5,6-trinitrochlorobenzene
- 2,6-dinitrochlorobenzene
- 2,6-dibromochlorobenzene
- 2-(dimethylamino)ethyl alcohol
- 2-[3-[4-(2-dimethylamino)ethyl]phenoxy]ethanol
- 2-furaldehyde
- 2-methyl-2-propanol
- 3,3'-dichlorodiphenyl ether
- 3,4-dichlorodiphenyl ether
- 3-aminobenzene
- 3-nitrotoluene
- 4-nitrotoluene
- 4-nitrotoluene
- 4-tert-butylphenol
- 6-ethyl-2-naphthol
- [(3a,4,5,6-tetrahydro-2H-pyridin-2-ylidene)amino]phosphonic acid
- acrylic acid
- alpha,alpha,alpha-trichlorotoluene
- Aluminatesilicate
- aluminium hydroxide



Navigation

Query results

Section tree

Query



- 1,2-dichloro-4-nitrobenzene
- 1,2-dichlorobenzene
- 1,3-dimethylurea JR
- 1,3-dinitrobenzene
- 1-chloro-4-nitrobenzene
- 2(or 4)-(isopro
- 2,5,6-trimethyl
- 2,6-di-tert-but
- 2,6-di-tert-but
- 2,6-dibromo-4
- 2-(dimethylami
- 2-[3-[4-(3-chlo
- 2-dimethylamir
- 2-furaldehyde
- 2-methylpropa
- 3,3'-dichlorobe
- 3,4-dichloroani
- 3-aminomethyl-3,5,5-trimethylcyclohexylamine
- 3-nitrotoluene**
- 4-nitrotoluene
- 4-nitrotoluene
- 4-tert-butyltoluene
- 6-ethyl-2-toluidine
- [(3a,4,5,6,7,7a-hexahydro-4,7-methano-1H-inden
- [[[(phosphonomethyl)imino]bis[(ethylenenitrilo)bis(
- acrylic acid, monoester with propane-1,2-diol
- alpha,alpha,alpha-trichlorotoluene
- Aluminatesilicate
- aluminium hydroxide

Substance: 3-nitrotoluene / 3-nitrotoluene / EUROPEAN COMMISSION - European Chemicals Bureau

Substance identification

Chemical name 3-nitrotoluene

Legal entity flags



Legal entity EUROPEAN COMMISSION - European Chemicals Bureau / Ispra (VA) / Italy

Role in the supply chain

Role flags



Dossier creation assistant

Dossier creation successfully completed.



You can now view the dossier or return to the substance.

View dossier

Return to substance

Type of substance

Composition other:

Origin

Trade names

Name

Benzene,1-metil-3-nitro-

Von IUCLID 5 zur Agentur

Das Registrierdossier wird in IUCLID 5 erstellt, exportiert und dann an die Website der Europäischen Chemikalienagentur (REACH IT) geschickt

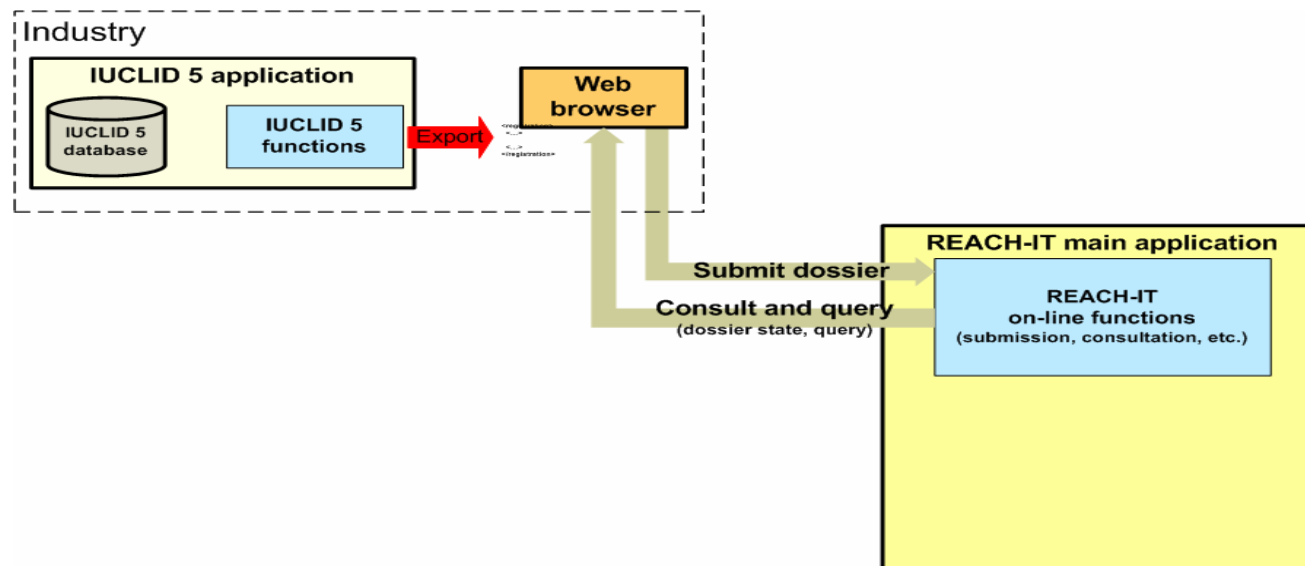

Was passiert danach?

- ❖ Nach einer **Validierung** durch die Agentur wird das Registrierdossier in der IUCLID 5 Datenbank der Agentur gespeichert.
- ❖ Das Dossier wird einem **Completeness Check** unterzogen, eine **Rechnung** wird ausgestellt und an den Registranten geschickt.
- ❖ Wenn das **Dossier komplett** ist und die **Gebühr bezahlt** wurde, bekommt der Registrant die **Registriernummer** zugeteilt.
- ❖ Alle Dossiers werden in der IUCLID 5 Datenbank gespeichert.

Von IUCLID zur öffentlichen Datenbank

Ausgewählte Daten des Registrierdossiers (entsprechend der Verordnung z.B. keine vertraulichen Daten) werden an die REACH-IT dissemination website (= Öffentliche Datenbank) weitergegeben.

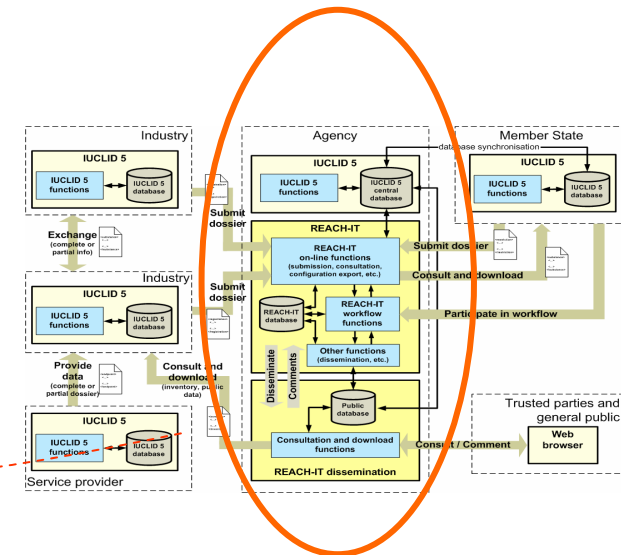
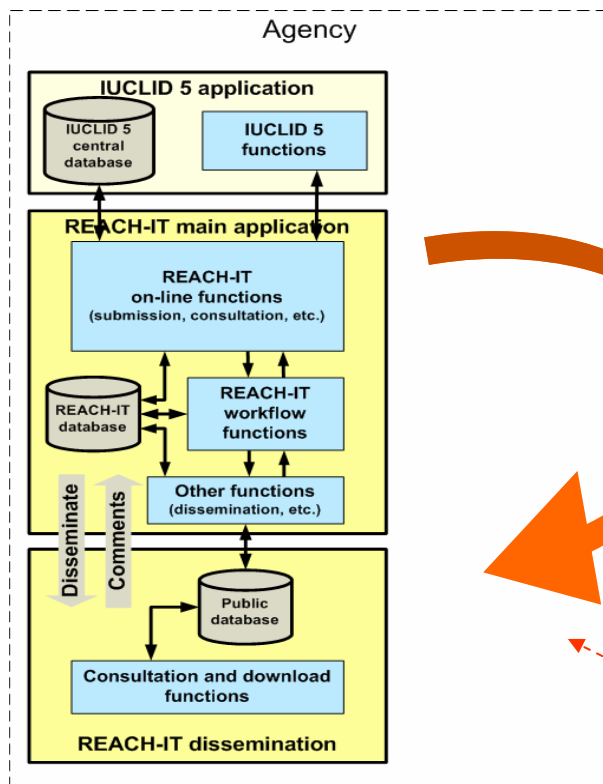

IUCLID 5 Entwicklung

IUCLID5

- ❖ Das System wird der Industrie kostenfrei zur Verfügung gestellt. (Termin: 30.3.2007)
- ❖ Es wird als Stand-alone und als Netzwerkversion zur Verfügung gestellt werden.
- ❖ Es läuft mit
 - Open Source Software (PostgreSQL, Tomcat) (lizenzfrei) oder
 - Kommerzieller Software (Oracle, Bea Weblogic) (lizenzpflichtig)

IUCLID5 System

IT architecture of IUCLID 5 – supported servers

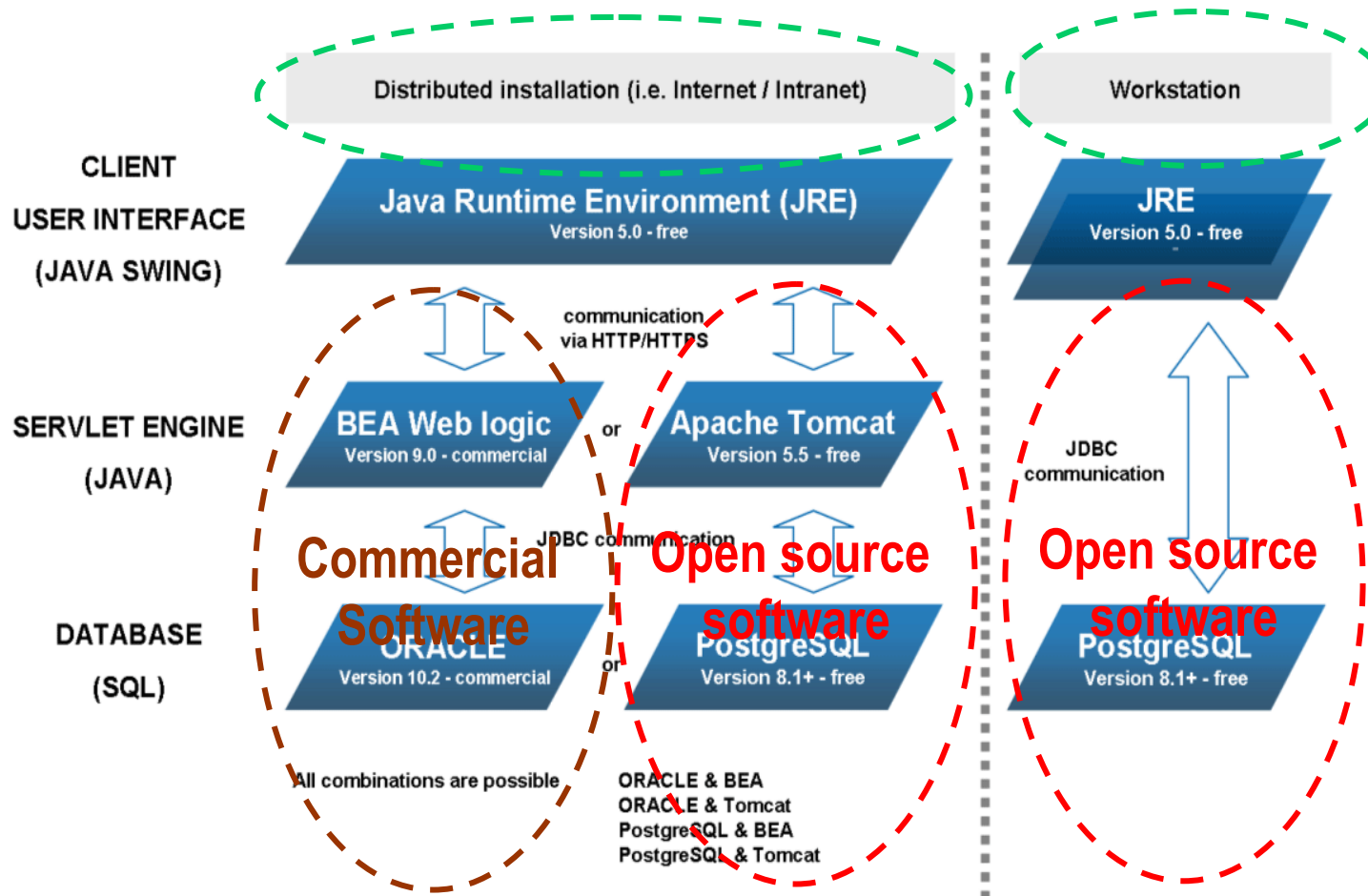

Fragen

- ❖ Wer wird die Registrierung durchführen?
- ❖ Soll IUCLID bei verschiedenen Tochterfirmen installiert werden?
- ❖ Gibt es Serviceeinheiten, die für verschiedene Bereiche arbeiten?
- ❖ Sind Consultants eingeschaltet?
- ❖ Muss es verschiedene Installationen geben, weil
 - Datensätze nicht gesperrt werden können
 - Sicherheit nur auf dem Level Installation gewährleistet werden kann
- ❖ Will man eine „Arbeitsdatenbank“ und eine „endgültige“ Datenbank einrichten?

Beispiel Bayer

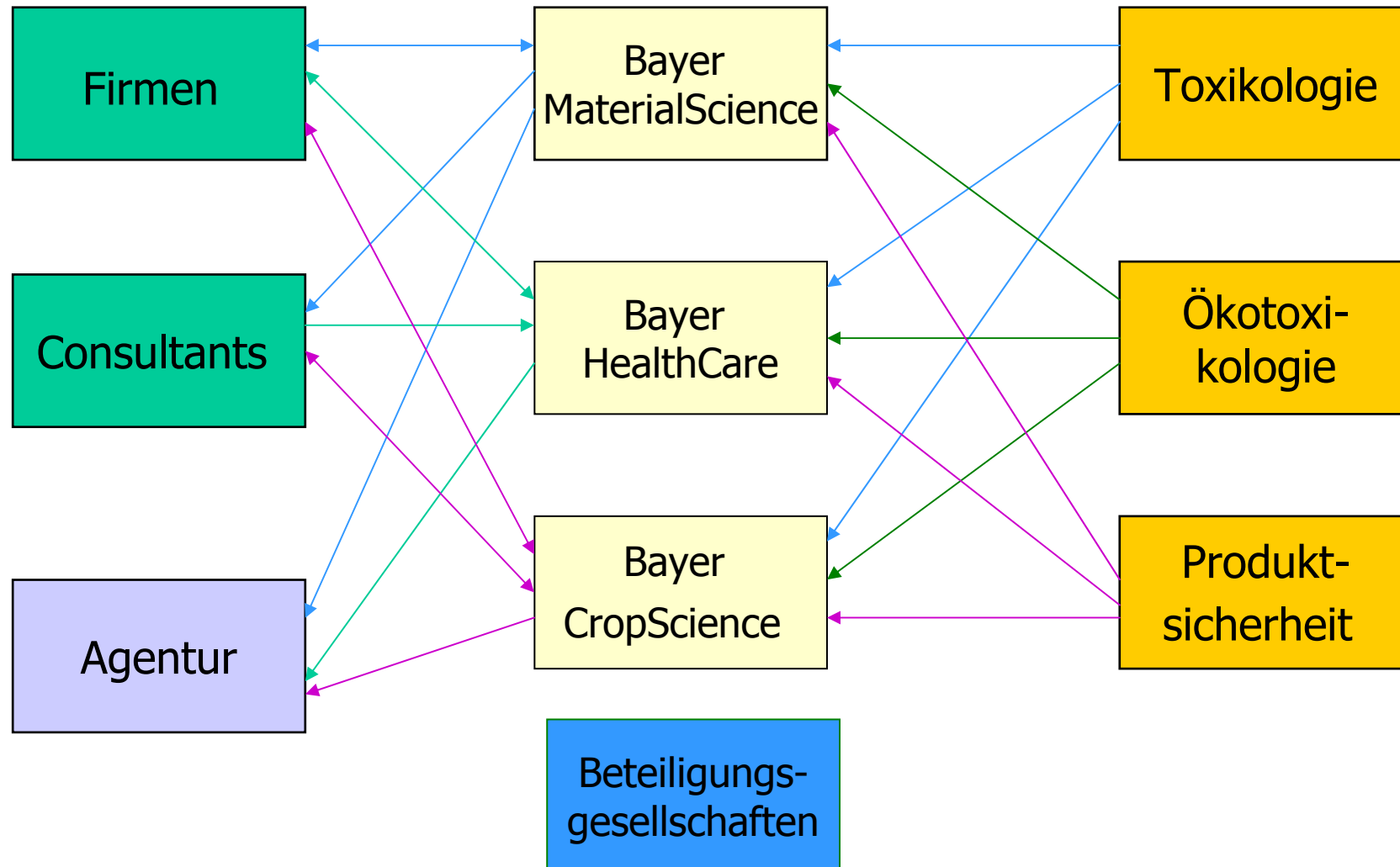

Registrierung für Beteiligungen

- ❖ Ein IUCLID Superuser kann mehrere „Legal entities“ anmelden.
- ❖ Er kann „on behalf of the affiliates“ vorregistrieren und registrieren.
- ❖ Er kann weitere Personen auf diese Installation zulassen.
- ❖ Er kann alle firmenbezogenen Angaben in REACH IT einsehen.

REACH IT

REACH IT für die Industrie

Legal Entity Management Dossier Submission
User Management Substance Inquiry
Pre-Registration Dossier Status Inquiry
SIEF Management DU reports
Joint Submission C&L Notifications

Dossiers in REACH IT

- ❖ Einige Dossiers können direkt in REACH-IT erstellt werden (ohne IUCLID)
- ❖ Diese Dossiers sind einfacher als die Registrierdossiers
- ❖ Grundvoraussetzung - Sie dürfen keine Robust Study Summaries enthalten
- ❖ Dossiers
 - Meldung in das Einstufungs- und Kennzeichnungsinventar
 - Downstream User Report oder Notifizierung
 - PPORD Dossier,
 - Antrag auf Zulassung
 - Notifizierung von Stoffen in Artikeln, etc...)

Weitere IT Tools

- ❖ Darüber hinaus wird es weitere IT Tools geben, die die Arbeit erleichtern sollen z.B.
 - Tools zur Bestimmung der Exposition
 - Tools zur Erstellung des CSA/CSR
- ❖ Diese Tools werden zur Zeit in RIP 3.2-2 Task III erarbeitet
- ❖ Zeitplan:
 - Analyse bis Ende 2007
 - Building Phase 2008

⇒ **zu spät für 01.06.2008!**
- ❖ Für die Industrie sind daneben auch noch diverse Schnittstellen zu den eigenen Systemen wichtig.



Bayer